

EXCELSIOR - SUPER LARIO - JOLLY - MARE - PATAY

POMPE A MANO

SERIE "EXCELSIOR – SUPER LARIO – JOLLY – MARE - PATAY "

HAND PUMPS

"EXCELSIOR – SUPER LARIO – JOLLY – MARE - PATAY " SERIES



EXCELSIOR



SUPER LARIO



JOLLY JUNIOR

APPLICAZIONI:

Adatte al pompaggio di acqua di mare e dolce, di liquidi corrosivi, di liquidi limpidi, per svuotamento sentine, travaso gasolio, olio, ecc..

APPLICATIONS:

Suitable for pump aggressive liquids, for fresh or sea water. Bilge emptying, tanks, diesel oil intake, oil, etc..

COSTRUZIONE:

GB:Corpo pompa in ghisa, parti interne in bronzo
B:Corpo pompa e parti interne in bronzo

CONSTRUCTION FEATURES:

GB:Body pump on cast iron, internal parts on bronze
B:Body pump and internal parts on bronze

GENERALITÀ:

EXCELSIOR:

Pompa semirotaiva a doppio effetto, aspirante-premente con una forte prevalenza.

SUPER LARIO:

Pompa autoadescante con pistoni a doppio effetto, raccomandata per applicazioni dove occorre aspirare da una notevole profondità (fino a 8m) anche in condizioni di impianto difficile (tubazioni non rettilinee).

JOLLY:

Pompa leggera ed economica con una grande portata di liquido a bassa prevalenza. Adatto a liquidi carichi di impurità.

MARE:

Pompa molto leggera, resistente ed ispezionabile, particolarmente indicata per i servizi di sentina e di emergenza

PATAY:

Pompa leggera, ispezionabile, non intasabile. Specifica per il travaso acqua, olii, fanghi e liquidi densi etc.

GENERALITY:

EXCELSIOR:

High head double acting semi-rotary wings pump, suitable for lifting and pushing of clear liquids

SUPER-LARIO:

Self priming double acting pistons pump, recommended for high suction lift installation (up to 9m) also in case of complex plant (not back straight pipe line).

JOLLY:

Light and cheap pump with a big water delivery at low head. Suitable for dirty liquids.

MARE:

Very light, strong and easy to check pump, usually used for bilge or emergency service

PATAY:

Light, easy to check and block resistant, usually used for water, oil, mud, and dense liquid intake

GARANZIA:

Due anni (vedi condizioni generali di vendita)

WARRANTY:

Two years (see our general sale conditions)

PRESTAZIONI:

PERFORMANCE:

MODELLO POMPA PUMP MODEL	VERSIONI VERSIONS		PORTATA l/min					DELIVERY l/min			
			10	15	24	35	45	50	60	70	100
			PORTATA m³/h					DELIVERY m³/h			
			0.6	0.9	1.4	2.1	2.7	3	3.6	4.2	6
			PREVALENZA TOTALE mH ₂ O					TOTAL MANOMETRIC HEAD mH ₂ O			
EXCELSIOR 0	X	X	30								
EXCELSIOR 1	X	X		30							
EXCELSIOR 2	X	X			30						
EXCELSIOR 3	X	X				30					
EXCELSIOR 4	X	X					30				
EXCELSIOR 5	X	X						30			
SUPER LARIO 2	X	X				30					
SUPER LARIO 3	X	X						30			
SUPER LARIO 4	X	X								30	
SUPER LARIO 5	X	X									30
JOLLY JUNIOR M.	INOX / STEEL									4	
T/A MARE	FIBERGLASS							15			
PATAY SD 45	NILON							9			
PATAY SD 120	NILON										6

Nota: prestazioni secondo EN ISO 9906 / Note: performance in accordance with EN ISO 9906
Prestazioni ottenute con 60 cicli il minuto / Performances relative to 60 cycles/minute

DIMENSIONI E PESI:

DIMENSION AND WEIGHT:

MODELLO POMPA PUMP MODEL	l	m	h	h'	f	DNa	DNm	Kg
JOLLY JUNIOR M.	300	82	40	630	-	40	40	4
T/A MARE	165	-	455	200	235	38X30	38X30	2.5
PATAY SD 45	120	-	500	165	210	26X19	26X19	2
PATAY DD 120	185	-	685	205	355	40X30	40X30	4.5

Nota: Le dimensioni sono indicative. Misure in mm / Notes: Dimensions are approximated. Dimensions in mm

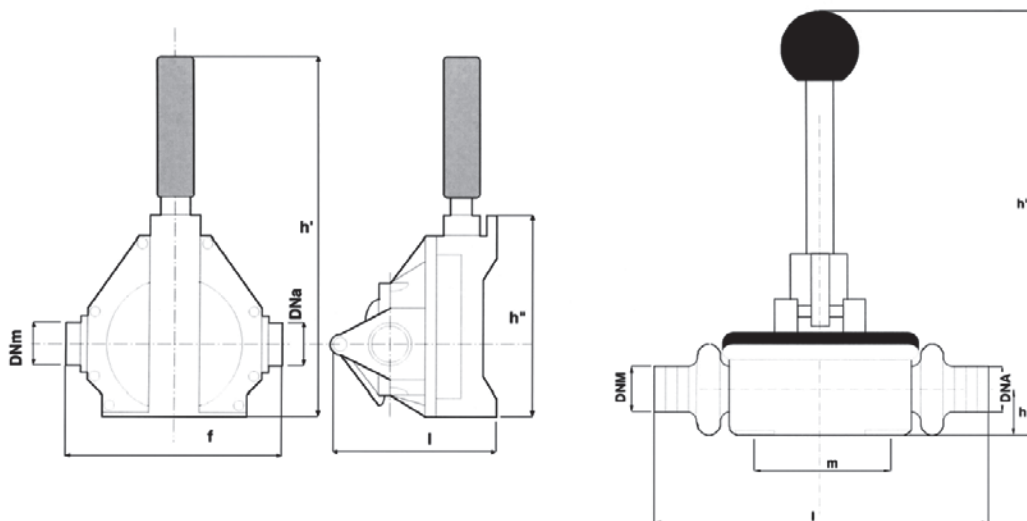

MARE - PATAY

JOLLY JUNIOR M

DIMENSIONI E PESI:

DIMENSION AND WEIGHT:

MODELLO POMPA	a	l	m	h	h'	f	DNa	DNm	Kg
PUMP MODEL									
EXCELSIOR 0	74	135	125	185	330	150	½"	½"	4
EXCELSIOR 1	75	135	150	215	360	175	¾"	¾"	5
EXCELSIOR 2	100	140	170	245	375	200	1"	1"	6
EXCELSIOR 3	110	165	190	275	450	225	1"1/4	1"1/4	9
EXCELSIOR 4	125	185	220	295	550	250	1"1/4	1"1/4	11
EXCELSIOR 5	145	185	250	335	570	290	1"1/2	1"1/2	14
SUPER LARIO 2	140	130	185	190	335	280	1"	1"	8
SUPER LARIO 3	165	165	210	220	410	330	1"1/4	1"1/4	11
SUPER LARIO 4	185	190	250	260	590	370	1"1/2	1"1/2	15
SUPER LARIO 5	240	220	340	280	610	480	2"	2"	25

Nota: Le dimensioni sono indicative. Misure in mm / Notes: Dimensions are approximated. Dimensions in mm

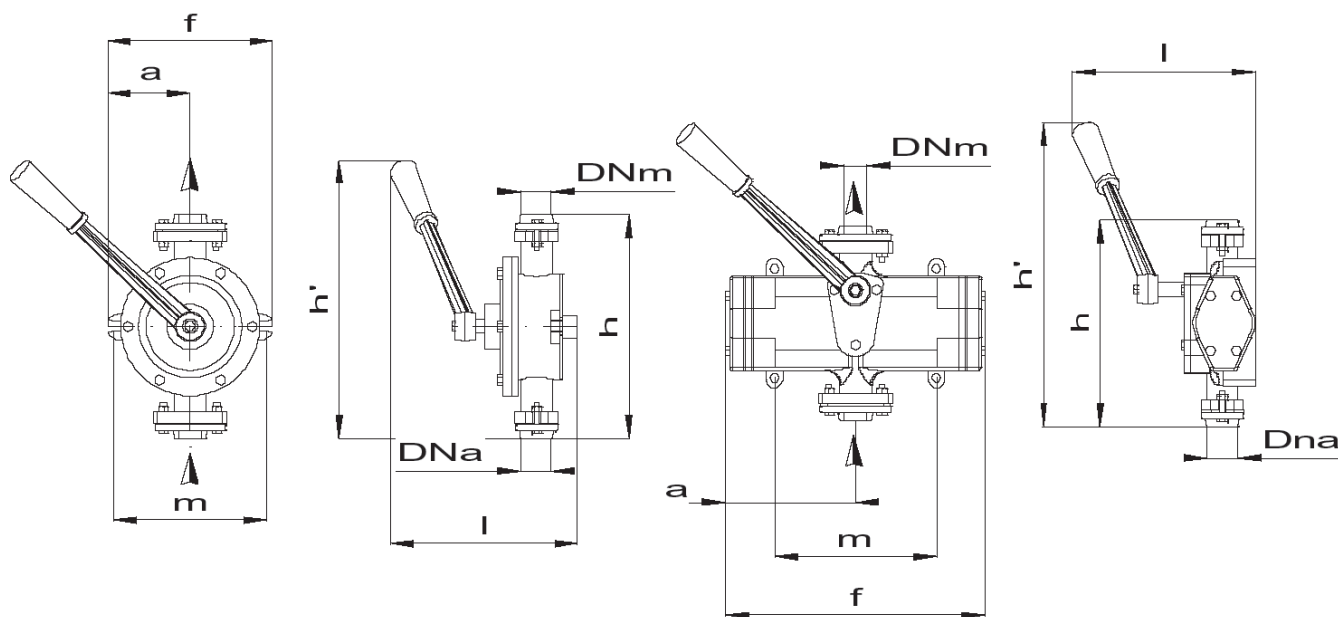

EXCELSIOR

SUPER LARIO